



Bucket Elevators and Conveyors



- Bucket Elevators
- Drag & Hy-Flight Conveyors
- Distributors
- Support Towers

Sukup Bucket Elevator

Head



- Low-impact head design
- Split-style hood allows for easy interior accessibility
- Lifting eyes are located on the hood of the elevator to ease hood assembly and removal
- Motor mount's dual screw adjustment allows you to align motor and belt for longer life. Allows proper belt tensioning while maintaining correct reducer torque arm angle.
- Adjustable throat wiper
- Bearing jack bolts for easy belt alignment
- Interior lip to keep moisture out and dust in
- Expanded metal-back urethane standard on 36" and larger
- Tapered bushing at pulley to eliminate lateral movement
- Externally mounted, heavy-duty pillow block bearings



Lifting Eyes



Dual Screw Adjusting Motor Mount

Intermediate



- Our squaring plates and alignment pins (patent pending) are placed at the top and bottom of every section to align trunking and eliminate the nightmare of twisted trunk sections, making assembly easier.
- Built square and parallel for no-hassle construction
- Sliding view port can be placed in two positions on inspection section
- Inspection section facilitates belt and splice installation
- Heavy welded frame with large removable panels on inspection section
- Heavy-gauge, huck-bolted or seam-welded units based on application
- Dust-tight and weather-tight protection
- Assembly-friendly tie angles

Squaring Plates and Alignment Pins

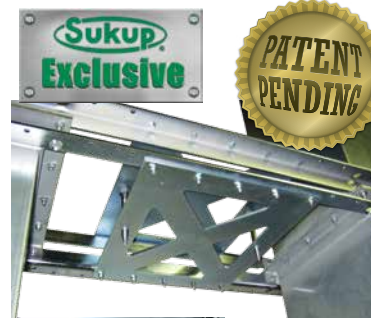

View Port

Boot



- Large, easy, tool-free access doors with a unique spring latch
- Large, easy-access clean-out doors with rollers on each end
- Hat section at bottom of clean-out doors to minimize contact with concrete
- Head and boot have UHMW seals at shafts
- Head and boot have heavy 1/4" structural frame
- Corrosion-resistant Acme screw take-up
- Bolted construction for easy repair and replacement



Access Door



Clean-out Door

Hoppers... Built to your Specifications

Standard Features

■ Turned, Ground, and Polished Shaft

Sukup utilizes a 1045, turned, ground, and polished (TG&P) shaft that allows your entire elevator to run smoothly.

■ Buckets

We use high-density, non-sparking, polyethylene buckets. Nylon, Urethane, and Steel buckets are optional when using highly abrasive materials. Vented buckets are also available.



■ Bearings

Ball Bearings come standard on head shaft sizes 3 7/16" and smaller. Sukup utilizes *Roller Bearings* for head shaft sizes 3 15/16" and larger. Roller Bearings are optional on all smaller bucket elevators. *Split Roller Bearings* come standard on 5 7/16" and larger head shaft sizes.

Squaring Plates Ease Assembly

"The squaring plates made the trunking easy to assemble. Having one end held together with squaring plates made it easy to hold the other end while trying to put an entire section of trunking together. The ladder and rest platforms also assembled easily."

-Bryan Blakstad,
Lodermeier's Inc. - Goodhue, MN



■ Low Impact Head Design

The Sukup bucket elevator head is a controlled design. Instead of the product bouncing off the interior of the head, it slides gently along the contour of the hood. Product damage and back-legging are minimized and the need for an internal shroud is eliminated.

■ Crown-Faced Pulley

This comes standard with any bucket elevator. Replaceable slide-lagging is ideal for the feed and grain industry.

■ Belting

Static conductive, Oil resistant, and Fire Retardant (SOFR) rubber belting is standard on all Sukup bucket elevators. Rubber belting has higher bolt retention properties which result in higher maximum bucket projection ratings, and provides maximum oil-based dust suppression additives. Sukup even supplies 10 extra feet of belting with every order to facilitate any belt-splicing configuration you would like to use.



Optional Features

■ Pressure Relief Door

NFPA compliant pressure relief doors come standard on 36" head section and larger. Optional on all others. This feature is also optional on trunking.

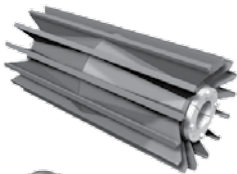

■ Winged Pulley

A Winged Pulley is a great option if you are concerned about material collecting on the pulley face.



■ Spiral Winged Pulley

Increased pulley-to-belt contact over winged pulley. Eliminates noise caused by winged pulleys.

Also Available:

Valving	Ceramic Chip Urethane Lining
Distributors	Bearing and Surface Sensors
Guy Brackets	Belt Misalignment Sensors
Shovel Pockets	Ladder & Cage Assembly
Motion Sensors	Reducer Backstops



■ Gravity Take-Up

Eases overall use of your bucket elevator. Maintains proper belt tension, and reduces maintenance.

■ Head Service Platform

One of the largest in the industry! Increases safety because there is more room to work. Available in 3 different sizes. Head platforms come pre-assembled from factory.

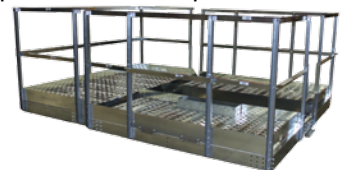

■ Distributor Platform

Available in sizes 3x8 ft. and 4x8 ft.

■ Standard and Flared Inlet Hoppers

Also available with optional 10 gauge abrasion-resistant liners.





Customized Conve

Drag Conveyors



Drag Conveyor Construction

- 11-gauge sides come standard on 9", 13" and 17" head and tail sections. 7-gauge sides come standard on 21" and 25" head and tail sections. All conveyor bodies utilize 11-gauge sides. Conveyor tops are 14-gauge construction. Conveyor bottoms come standard as 7-gauge construction.
- All standard conveyors are galvanized construction.
- Heavy-duty bearing mounts come in 1/4" or 3/8" construction.
- Optional abrasion-resistant liners on sides include 10-gauge, 3/16" and 1/4". Bottoms include 3/16", 1/4" and 3/8" thickness. Abrasion-resistant bottoms are painted.

Options

End Relief Door - Prevents damage to the conveyor in the event of a discharge plug.

Roller Return - These UHMW rollers come standard on 9", 12", and 16" wide conveyors.

Rail Return - Comes standard on 21" wide or wider conveyors. Optional on 12" and 16" wide conveyors. Manufactured with 7-gauge galvanized construction.

Reversing Feature - This feature can take grain in multiple directions and is a great addition if you are looking to unload into two separate bins.

Inlets - Bypass drive-over hoppers have an adjustable shroud to control flow. Bypass drive-over hoppers with bar grating are available in 6', 8' and 10' lengths. Bypass inlet hoppers are available in 3' and 4' lengths.

Intermediate Discharge Gates - Can act as a separate discharge location in addition to the head anywhere along the trough. Made of 7-gauge construction.

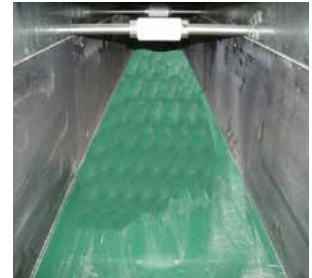

Abrasion Resistant Liner



End Relief Door

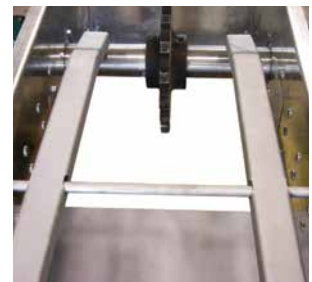

Rail Return

■ Turned, Ground and Polished Shaft

Sukup utilizes a higher precision 1045, turned, ground and polished (TG&P) shaft that allows your entire conveyor to run smoothly. All UHMW shaft seals are 1/4" thick.

■ Removable Bearing, Sprocket and Shaft

The bearing, sprocket and shaft are all one removable unit on Sukup Drag Conveyors for easier maintenance. The entire assembly can be removed without having to separate the shaft from the bearings or the sprocket.



Standard Features on Drag

■ Pre-Assembled Chains and Paddles

Our conveyor chains come pre-assembled with paddles to help speed installation. They are engineered for each specific unit and are either roller bushed or welded steel. Chain pitch will vary from 2.609" up to 6.125" with an average ultimate strength of up to 230,000 lbs. UHMW paddles, 1/2" thick, eliminate the steel-to-steel contact.



yors - Now That's a Solution

Hy-Flight Conveyors

Hy-Flight Conveyor Construction

- Bolted "tongue" to prevent return panel from sagging.
- Optional abrasion-resistant liners on sides include 10-gauge, $\frac{3}{16}$ ", and $\frac{1}{4}$ ". Bottoms include $\frac{3}{16}$ ", $\frac{1}{4}$ ", and $\frac{3}{8}$ " thickness. Abrasion-resistant bottoms are painted.
- Heavy-duty bearing mounts come in $\frac{1}{4}$ " or $\frac{3}{8}$ " construction.
- 11-gauge sides come standard on 13" and 17" head sections. 7-gauge sides come standard on 21" and 25" head sections. All conveyor bodies utilize 11-gauge sides. Conveyor tops are 14-gauge construction. Conveyor bottoms come standard as 7-gauge construction.
- All standard conveyors are galvanized construction.



Modular Curve Section

Options

Modular Curve Section - If a straight incline just won't fit, adding a curve section might do the trick. The curve sections are available from 10° to 50° inclines in 5° increments.

Inlets - Bypass drive-over hoppers have an adjustable shroud to control flow. Bypass drive-over hoppers with bar grating are available in 6', 8', and 10' lengths. Bypass inlet hoppers are available in 3' and 4' lengths.

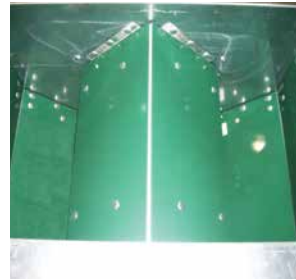

Inlets

and Hy-Flight Conveyors

Removable Bottom

Moving a lot of grain? We made it easy to replace the worn out bottom without replacing the entire body of the conveyor - an additional feature that can save you both time and money. Consider our standard 7-gauge or optional $\frac{3}{16}$ ", $\frac{1}{4}$ ", and $\frac{3}{8}$ " abrasion-resistant bottoms.



Cover Clamp

Our cover clamps ensure the cover locks tight to the conveyor body.

Conveyor Covers

Our patented conveyor covers are exclusive to Sukup and will not be found on competitors' products. Our conveyor cover design reduces the number of tools needed for installation and does not require any sealant at the joints. An added bonus... No water running into your conveyor!



Sukup
Exclusive



Bucket Elevator Specifications

Pulley Diameter	Bu/Hr	Bucket		Pulley RPM	Belt Speed (FPM)	Head Shaft*
		Size	Spacing			
24"	1500	9x5"	8 1/2"	59	371	2 3/16"
24"	2000	9x6"	9"	59	371	2 3/16"
24"	2500	9x6"	8"	64	402	2 7/16"
24"	3000	9x6"	7"	67	421	2 7/16"
24"	3500	9x6" LP**	6"	70	440	2 7/16"
24"	4000	9x6" LP**	5"	67	421	2 7/16"
24"	4500	9x6" LP**	5"	69	434	2 7/16"
24"	5000	9x6" LP**	5"	77	484	2 7/16"
30"	4000	12x6"	9"	67	526	2 7/16"
30"	4500	12x7"	9"	57	448	2 7/16"
30"	5000	12x7"	9"	64	503	2 7/16"
30"	5500	13x7"	9"	61	479	2 7/16"
30"	6000	13x7"	9"	66	518	2 7/16"
30"	6500	13x7"	8"	64	503	2 7/16"
30"	7000	13x7"	8"	68	534	2 7/16"
30"	7500	14x7"	8"	69	542	2 7/16"
36"	6000	13x7"	9"	55	518	2 7/16"
36"	6500	13x7"	9"	60	565	2 7/16"
36"	7000	13x7"	8"	57	537	2 7/16"
36"	8000	14x7"	8"	62	584	2 15/16"
36"	9000	13x7" LP**	6"	58	547	2 15/16"
36"	10,000	13x7" LP**	6"	64	603	2 15/16"
42"	8000	14x7"	9"	59	649	3 7/16"
42"	9000	14x7"	8"	59	649	3 7/16"
42"	10,000	16x7"	8"	58	638	3 7/16"
42"	11,000	16x7"	8"	62	682	3 7/16"
42"	12,000	16x8"	10"	58	638	3 7/16"
42"	13,000	16x8"	9"	57	627	3 7/16"
42"	14,000	16x8"	9"	61	671	3 7/16"
42"	15,000	18x8"	9"	58	638	3 7/16"
48"	15,000	18x8"	10"	56	704	3 7/16"
48"	20,000	(2) 12x8"	10"	57	716	3 15/16"
48"	25,000	(2) 16x8"	10 1/2"	56	704	4 7/16"
48"	30,000	(2) 18x8"	10"	56	704	4 7/16"
48"	40,000	(3) 16x8"	10"	56	704	4 15/16"
48"	50,000	(3) 20x8"	10"	56	704	5 7/16"

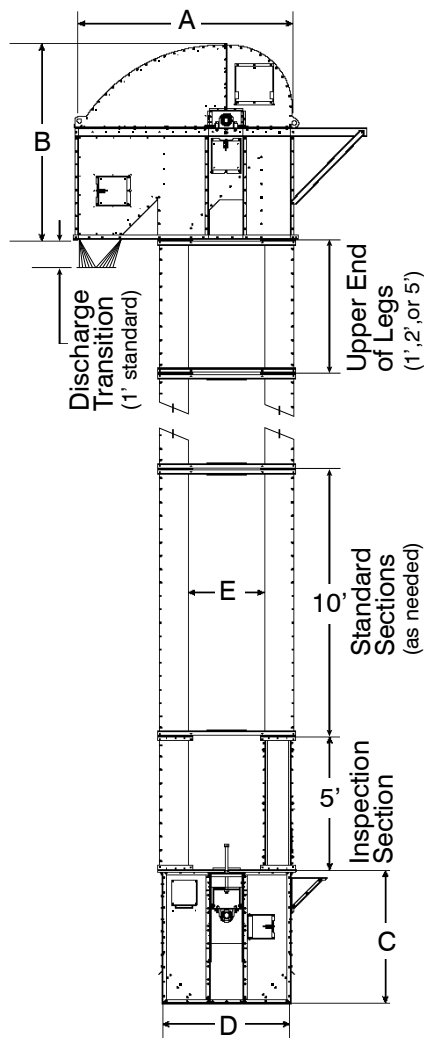

* Value dependent upon height
 ** Low Profile



Pulley Diameter	Bu/Hr	Head Gauge	Hood Gauge	Boot Shaft*	Boot Gauge	Trunking Gauge	Trunking Size	Nominal Dimensions				
								A	B	C	D	E
24"	All	12ga	14ga	1 7/16"	10ga	14ga	13x10"	66"	60"	60"	43"	23"
30"	All	8ga	12ga	1 15/16"	10ga	14ga	18x12"	83"	75"	60"	52"	28"
36"	All	8ga	12ga	2 3/16"	10ga	14ga	18x12"	96"	88"	60"	58"	34"
42"	All	8ga	12ga	2 7/16"	7ga	12ga	22x14"	108"	101"	72"	68"	40"
48"	15,000	8ga	12ga	2 7/16"	7ga	12ga	22x14"	120"	110"	72"	74"	46"
48"	20,000	8ga	12ga	2 7/16"	1/4"	12ga	32x14"	120"	110"	72"	74"	46"
48"	25,000	8ga	12ga	2 15/16"	1/4"	12ga	40x14"	120"	110"	72"	74"	46"
48"	30,000	8ga	12ga	2 15/16"	1/4"	12ga	44x14"	120"	110"	72"	74"	46"
48"	40,000	8ga	12ga	3 7/16"	1/4"	12ga	58x14"	120"	110"	72"	74"	46"
48"	50,000	8ga	12ga	3 7/16"	1/4"	12ga	70x14"	120"	110"	72"	74"	46"

Drag Conveyor Specifications

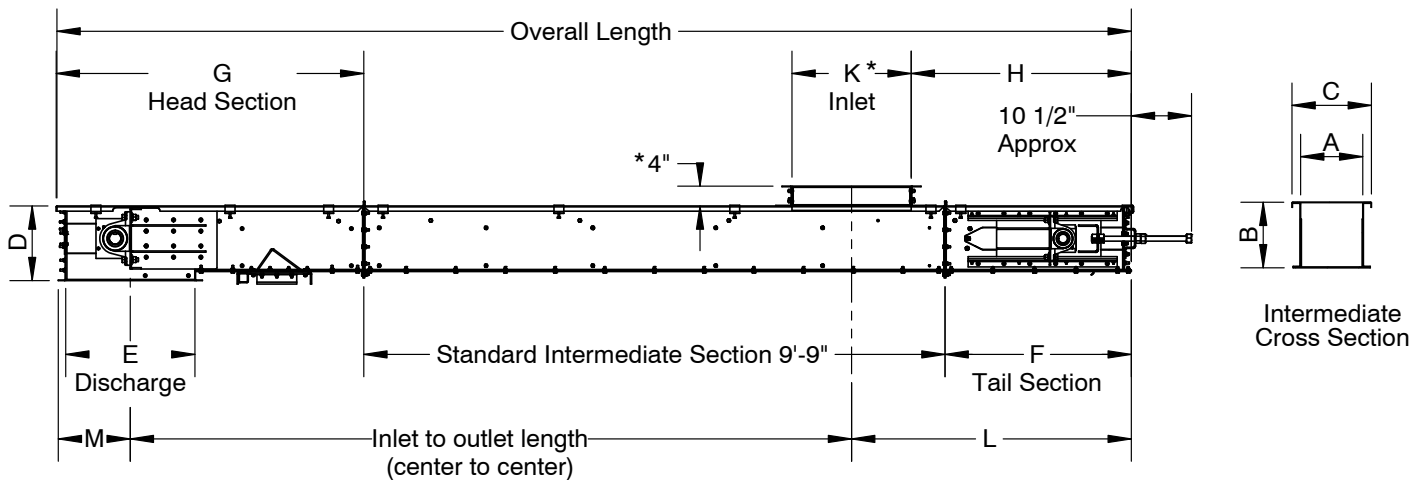

* Contact Sukup Manufacturing Co. for dimensional information on other styles of inlets.
 ** Estimates only. Contact Sukup Manufacturing Co. for actual dimensions.

Model #	Capacities Bu/Hr				Inside Width A	Inside Height B	Overall Width C	Head Height D	Discharge Opening E	Tail Length F	Head Length G	Min. Inlet Distance H**	Inlet Length K*	Min. Length L**	Min. Length M**
	100 FPM	125 FPM	150 FPM	180 FPM											
909	1352	1691	2029	2434	9 1/2"	9"	12"	15"	26"	37 1/2"	61 1/2"	33"	24"	45"	14 1/2"
913	2374	2968	3562	4274	9 1/2"	13"	12"	15"	26"	37 1/2"	61 1/2"	41"	24"	53"	14 1/2"
1209	1903	2379	2854	3425	12 1/2"	9"	15 1/2"	15"	26"	37 1/2"	61 1/2"	33"	24"	45"	14 1/2"
1213	3334	4168	5002	6002	12 1/2"	13"	15 1/2"	15"	26"	37 1/2"	61 1/2"	41"	24"	53"	14 1/2"
1217	4829	6036	7244	8693	12 1/2"	17"	15 1/2"	19"	26"	37 1/2"	61 1/2"	50"	24"	62"	14 1/2"
1609	2525	3156	3787	4545	16 1/2"	9"	19 1/2"	15"	26"	37 1/2"	61 1/2"	33"	24"	45"	14 1/2"
1613	4425	5531	6637	7965	16 1/2"	13"	19 1/2"	15"	26"	37 1/2"	61 1/2"	41"	24"	53"	14 1/2"
1617	6408	8010	9612	11,535	16 1/2"	17"	19 1/2"	19"	26"	37 1/2"	61 1/2"	50"	24"	62"	14 1/2"
1621	8472	10,590	12,708	15,249	16 1/2"	21"	19 1/2"	23"	36"	71 1/2"	71 1/2"	68"	24"	80"	19 1/2"
2109	3225	4031	4837	5805	21"	9"	24"	15"	26"	37 1/2"	61 1/2"	33"	24"	45"	14 1/2"
2113	5651	7064	8477	10,173	21"	13"	24"	15"	26"	37 1/2"	61 1/2"	41"	24"	53"	14 1/2"
2117	8185	10,231	12,277	14,733	21"	17"	24"	19"	26"	37 1/2"	61 1/2"	50"	24"	62"	14 1/2"
2121	10,820	13,526	16,231	19,477	21"	21"	24"	23"	36"	71 1/2"	71 1/2"	68"	24"	80"	19 1/2"
2125	14,118	17,647	21,176	25,412	21"	25"	24"	27"	36"	71 1/2"	71 1/2"	80"	24"	92"	19 1/2"
2717	10,555	13,193	15,832	18,999	27"	17"	30"	19"	26"	37 1/2"	61 1/2"	50 1/2"	27"	64"	14 1/2"
2721	13,953	17,441	20,930	25,116	27"	21"	30"	23"	36"	71 1/2"	71 1/2"	67 1/2"	27"	81"	19 1/2"
2725	18,204	22,756	27,307	32,768	27"	25"	30"	27"	36"	71 1/2"	71 1/2"	80 1/2"	27"	94"	19 1/2"
3317	12,924	16,155	19,387	23,264	33"	17"	36"	19"	26"	37 1/2"	61 1/2"	50"	30"	65"	14 1/2"
3321	17,086	21,357	25,628	30,754	33"	21"	36"	23"	36"	71 1/2"	71 1/2"	68"	30"	83"	19 1/2"
3325	22,291	27,864	33,437	40,124	33"	25"	36"	27"	36"	71 1/2"	71 1/2"	80"	30"	95"	19 1/2"

Note: All 9" conveyors have tapered head sections.

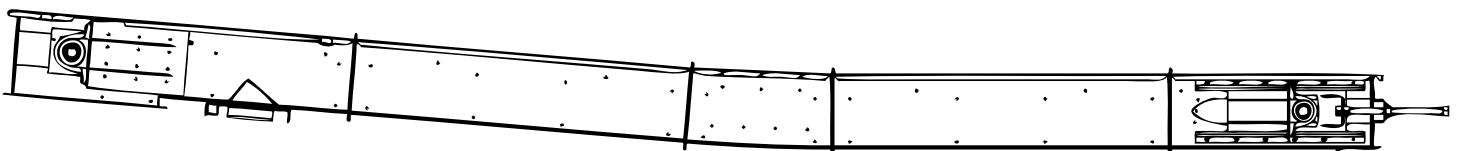

Drag Conveyor with Bend and Incline Sections

- Bend and incline sections are used to increase discharge height.
- 5° bend and incline sections give you 1 1/32" of rise for every foot of run.
- 10° bend and incline sections give you 2 1/8" of rise for every foot of run.
- Note: use of 10° bend and incline sections requires a double paddle chain.

Hy-Flight Conveyor Specifications

Model #	Capacities Bu/Hr				Inside Width A	Inside Height B	Overall Width C	Head Height DH	Tail Height DT	Radius	Slope	P1	N1	68" Radius		84" Radius	
	100 FPM	125 FPM	150 FPM	180 FPM										Q	R	Q	R
HF1213	2176	2719	3263	3916	12 1/2"	14 1/2"	15 1/2"	20 3/4"	18 1/2"	68"	10°	3 1/8"	17 3/4"	11 13/16"	1"	14 9/16"	1 1/4"
HF1613	2887	3609	4331	5197	16 1/2"	14 1/2"	19 1/2"	20 3/4"	18 1/2"	68"	15°	4 11/16"	17 3/8"	17 5/8"	2 5/16"	21 3/4"	2 7/8"
HF1617	3811	4764	5716	6860	16 1/2"	18 1/2"	19 1/2"	24 3/4"	22 1/2"	68"	20°	6 3/16"	16 15/16"	23 1/4"	4 1/8"	28 3/4"	5 1/16"
HF2117	4867	6084	7301	8761	21"	18 1/2"	24"	24 3/4"	22 1/2"	68"	25°	7 5/8"	16 5/16"	28 3/4"	6 3/8"	35 1/2"	7 7/8"
HF2121	6047	7559	9071	10,885	21"	22 1/2"	24"	28 3/4"	27"	68"	30°	9"	15 5/16"	34"	9 1/8"	42"	11 1/4"
HF2721	7798	9747	11,697	14,036	27"	22 1/2"	30"	28 3/4"	27"	84"	35°	10 5/16"	14 3/4"	39"	12 5/16"	48 3/16"	15 3/16"
HF3321	9548	11,935	14,322	17,186	33"	22 1/2"	36"	28 3/4"	27"	84"	40°	11 9/16"	13 13/16"	43 11/16"	15 15/16"	54"	19 5/8"
HF3325	11,411	14,264	17,116	20,540	33"	26 1/2"	36"	32 3/4"	31"	84"	45°	12 3/4"	12 3/4"	48 1/16"	19 15/16"	59 3/8"	24 5/8"
											50°	13 13/16"	11 9/16"	52 1/16"	24 1/4"	64 3/8"	30"

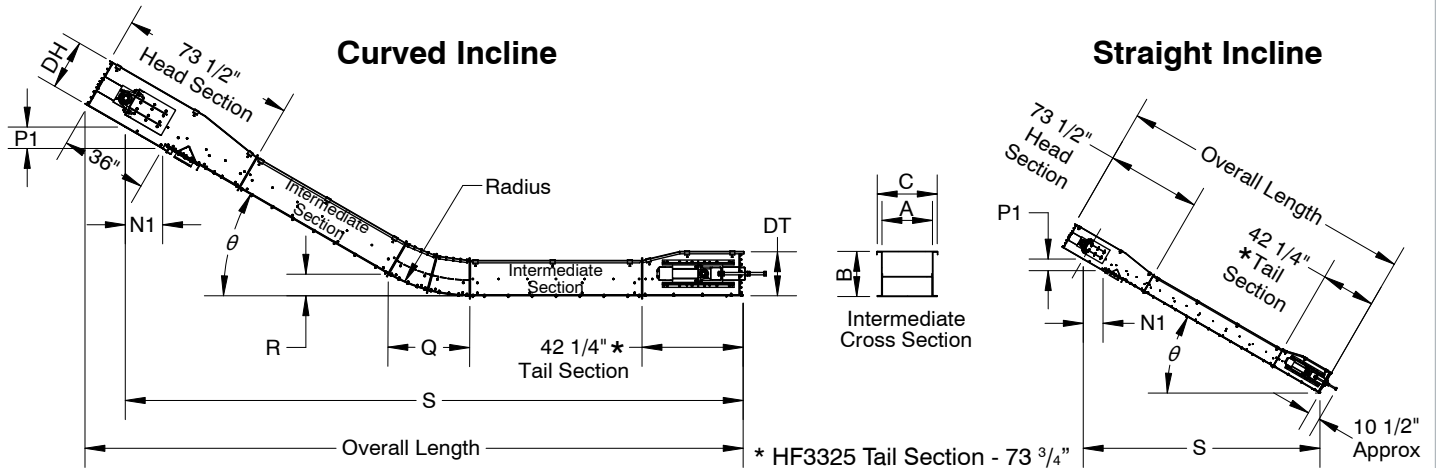

By-Pass Hopper

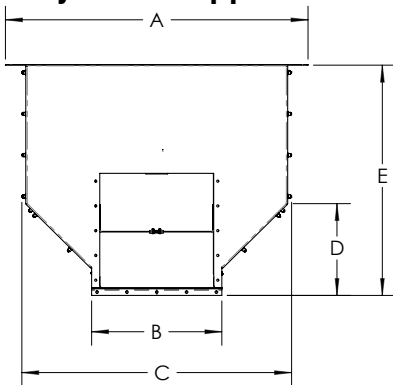

Wide By-Pass Hopper

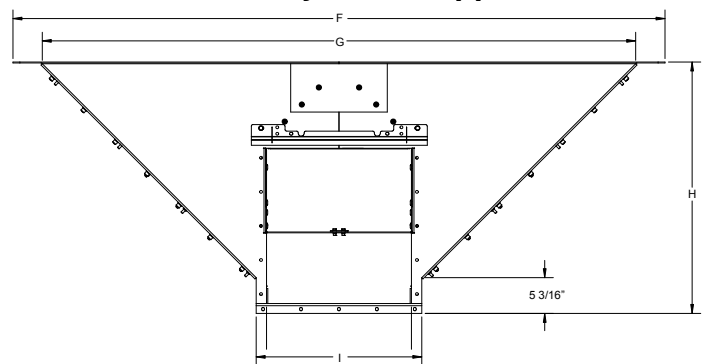

Model #	By-Pass Inlets Available Lengths of 3', and 4'					By-Pass w/ Drive-Over Grating Available in base Lengths of 6', 8', and 10'*					Wide By-Pass Hopper			
	A	B	C	D	E	A	B	C	D	E	F	G	H	I
1213	44"	15 1/2"	38"	15 3/8"	27 1/2"	55 3/4"	15 1/2"	49 11/16"	21 1/4"	42 7/16"	61"	52 3/4"	24 1/16"	15 1/2"
1613	44"	19 1/2"	38"	13 1/2"	27 1/2"	55 3/4"	19 1/2"	49 11/16"	19 1/8"	42 7/16"	69"	60 3/4"	26 1/16"	19 1/2"
1617	44"	19 1/2"	38"	13 1/2"	31 1/2"	55 3/4"	19 1/2"	49 3/4"	19 1/8"	42 7/16"	77"***	68 3/4"***	30 1/16"***	19 1/2"
2117	44"	24"	38"	11 1/4"	33 1/2"	55 3/4"	24"	49 11/16"	16 15/16"	42 7/16"	86 1/2"	78"	32 7/16"	24"
2121	44"	24"	38"	11 1/4"	37 1/2"	55 3/4"	24"	49 11/16"	16 15/16"	42 7/16"	94 1/2"	86"	36 7/16"	24"
2721	44"	30 1/2"	38"	11 1/4"	41 1/2"	55 3/4"	30"	49 3/4"	13 15/16"	42 7/16"	106 1/2"***	98"***	39 7/16"***	30"
3321	56"	36"	50"	17 1/4"	44 1/2"	67 3/4"	36"	61 3/4"	19 1/8"	54 1/2"	118 1/2"***	110"***	42 7/16"***	36"
3325	56"	36"	50"	17 1/4"	46 1/2"	67 3/4"	36"	61 3/4"	17"	54 1/2"	126 1/2"***	118"***	46 7/16"***	36"

* Available in longer overall lengths using multiple hoppers that bolt to each other. Contact Sukup Manufacturing Co. for further information.

** Estimates only. Contact Sukup Manufacturing Co. for actual dimensions.

NEW - Sukup Distributors



Distributors

- 45° wing-back design; heavy-duty, galvanized compact construction; dust and weather tight to reduce contamination.
 - Dense, bristle brush seal to minimize product build-up inside the distributor and leakage of product into adjacent bins.
 - Top and bottom bearing for smooth, easy operation
 - Positive locking system for precise spout positioning
 - Discharge stubs manufactured from 10 ga abrasion resistant steel
 - Hinged door for inspection and maintenance
 - Internal spout bolted for easy parts replacement.
- Optional: lined with 1/4" EMB urethane
- Standard cable control kit

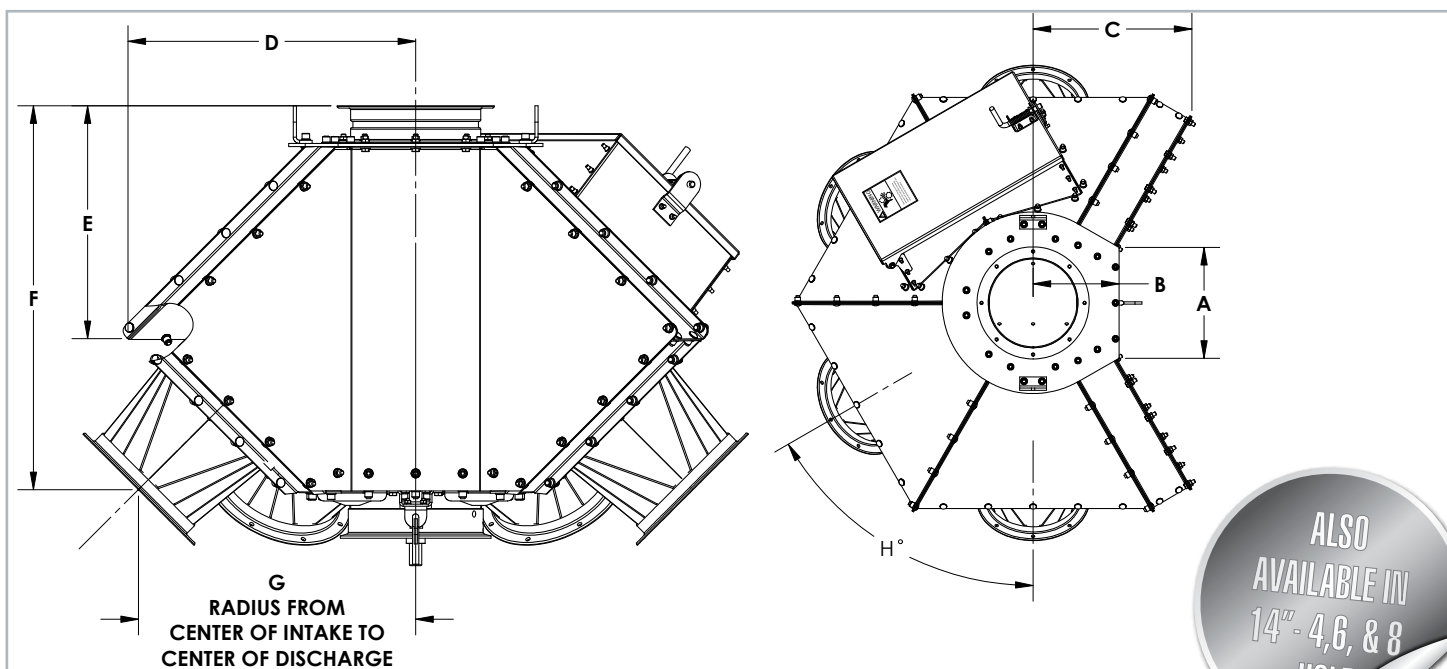

ALSO
AVAILABLE IN
14" - 4, 6, & 8
HOLE

Size	Sukup Distributor							
	A	B	C	D	E	F	G	H
8" - 4 Duct	12 ³ / ₈ "	9 ¹⁹ / ₃₂ "	17 ⁵ / ₈ "	22 ¹⁵ / ₁₆ "	18 ⁹ / ₁₆ "	30 ¹⁹ / ₃₂ "	22 ³ / ₃₂ "	60°
8" - 6 Duct	10 ³ / ₈ "	9 ¹⁹ / ₃₂ "	17 ⁵ / ₈ "	24 ¹⁵ / ₁₆ "	20 ³¹ / ₃₂ "	32 ⁹ / ₃₂ "	24 ⁷ / ₁₆ "	40°
8" - 8 Duct	10"	9 ¹⁹ / ₃₂ "	19 ²⁹ / ₃₂ "	30 ⁵ / ₃₂ "	25 ⁷ / ₈ "	37 ⁹ / ₁₆ "	29 ²¹ / ₃₂ "	30°
10" - 4 Duct	12 ³ / ₈ "	9 ¹⁹ / ₃₂ "	17 ⁵ / ₈ "	22 ¹⁵ / ₁₆ "	18 ⁹ / ₁₆ "	30 ¹⁹ / ₃₂ "	22 ³ / ₃₂ "	60°
10" - 6 Duct	12 ³ / ₈ "	9 ¹⁹ / ₃₂ "	20 ¹ / ₁₆ "	29 ¹ / ₂ "	24 ¹ / ₂ "	36 ¹⁷ / ₃₂ "	28 ⁵ / ₈ "	40°
10" - 8 Duct	11 ⁹ / ₁₆ "	9 ¹⁹ / ₃₂ "	22 ¹⁹ / ₃₂ "	34 ³ / ₄ "	30 ³ / ₁₆ "	42 ⁷ / ₃₂ "	33 ²⁹ / ₃₂ "	30°
12" - 4 Duct	14 ³ / ₈ "	11 ¹ / ₃₂ "	21 ¹⁷ / ₃₂ "	27 ¹⁵ / ₁₆ "	21 ¹⁵ / ₁₆ "	35 ⁷ / ₃₂ "	26 ¹ / ₁₆ "	60°
12" - 6 Duct	12 ⁵ / ₁₆ "	12 ³ / ₃₂ "	23 ²⁷ / ₃₂ "	33 ²⁷ / ₃₂ "	28 ³ / ₃₂ "	41 ¹¹ / ₃₂ "	32 ¹ / ₈ "	40°
12" - 8 Duct	14 ³ / ₈ "	11 ¹ / ₃₂ "	25 ¹⁵ / ₃₂ "	39"	35 ³ / ₈ "	47 ⁹ / ₁₆ "	38 ¹¹ / ₃₂ "	30°

New - Sukup Support Towers



Leg Support Towers

Sukup leg support towers are an excellent choice for supporting bucket elevators. Towers eliminate the need for guying cables that clutter your facility and eat up valuable real estate. In addition to providing the vertical support for the elevator legs, the towers can be designed to support bulk weighers, cleaners, and distributors – either inside or outside the tower.



Standard Features

- Powder-coated finish; optional hot-dipped galvanized
- Heavy duty bolted construction; knock-down design for economical shipping
- Modules available in 20' and 10' sections
- Computer engineered, strength-staged for wind, seismic, cleaner, catwalk and other loads
- Unique angle iron bracing design

Optional Features

- Access bracing to accommodate spouting, catwalks, conveyors, etc.
- Catwalk support beams
- Stairs – wrap around or switch back
- Interior or exterior platforms
- Ladder and cage system



Sukup Manufacturing Co. provides the information contained within this brochure to assist you in choosing the optimal equipment for your situation. Sukup specifications should only be used as estimates, and not as a warranty, expressed or implied, of how a particular Sukup unit will perform under your varying operating conditions. Because we are continually improving Sukup products, changes may occur that may not be reflected in the specifications.



Sukup Manufacturing Co. ■ www.sukup.com

Box 677 ■ 1555 255th St. ■ Sheffield, IA 50475-0677
ph 641.892.4222 ■ fx 641.892.4629 ■ email info@sukup.com

Distribution Centers

Arcola, IL 61910
980 E. State Rte. 133
ph 217.268.3026
fx 217.268.3522

Aurora, NE 68818
1705 Hwy. 34 E.
ph 402.694.5922
fx 402.694.5921

Cameron, MO 64429
7426 NE 352nd St.
ph 816.649.2226
fx 816.649.2225

Defiance, OH 43512
7724 Rte. 66 N.
ph 419.784.9871
fx 419.784.9872

Jonesboro, AR 72403
5917 E. Johnson Ave.
ph 870.932.7547
fx 870.933.8946

Watertown, SD 57201
2701 Piper Ave.
ph 605.882.6697
fx 605.884.0467